

Models:

- 57000 - 3-1/2" Non-Vacuum
- 57001 - 3-1/2" Basic Vacuum
- 57002 - 3-1/2" Deluxe Vacuum
- 57003 - 3-1/2" Vac-Ready
- 57004 - 3-1/2" Central Vac-Ready
- 57015 - 5" Non-Vacuum
- 57016 - 5" Basic Vacuum
- 57017 - 5" Deluxe Vacuum
- 57018 - 5" Vac-Ready
- 57019 - 5" Central Vac-Ready
- 57021 - 5" Basic Vac w/overskirt
- 57022 - 5" Deluxe Vac w/overskirt

- 57023 - 5" Vac-Ready w/overskirt
- 57024 - 5" Central Vac-Ready w/overskirt
- 57026 - 6" Non-Vacuum
- 57027 - 6" Basic Vacuum
- 57028 - 6" Deluxe Vacuum
- 57029 - 6" Vac-Ready
- 57030 - 6" Central Vac-Ready
- 57032 - 6" Basic Vacuum w/overskirt
- 57033 - 6" Deluxe Vacuum w/overskirt
- 57034 - 6" Vac-Ready w/overskirt
- 57035 - 6" Central Vac-Ready w/overskirt

Parts Page Reorder No. PD97•21
 Effective March, 1997
 Supersedes PD96•01

Dynorbital® Supreme

Random Orbital Sander, 3/16" Dia. Orbit.

⚠ WARNING

Always operate, inspect and maintain this tool in accordance with the Safety Code for portable air tools (ANSI B186.1) and any other applicable safety codes and regulations. Please refer to Dynabrade's Warning/Safety Operating Instructions for more complete safety information.

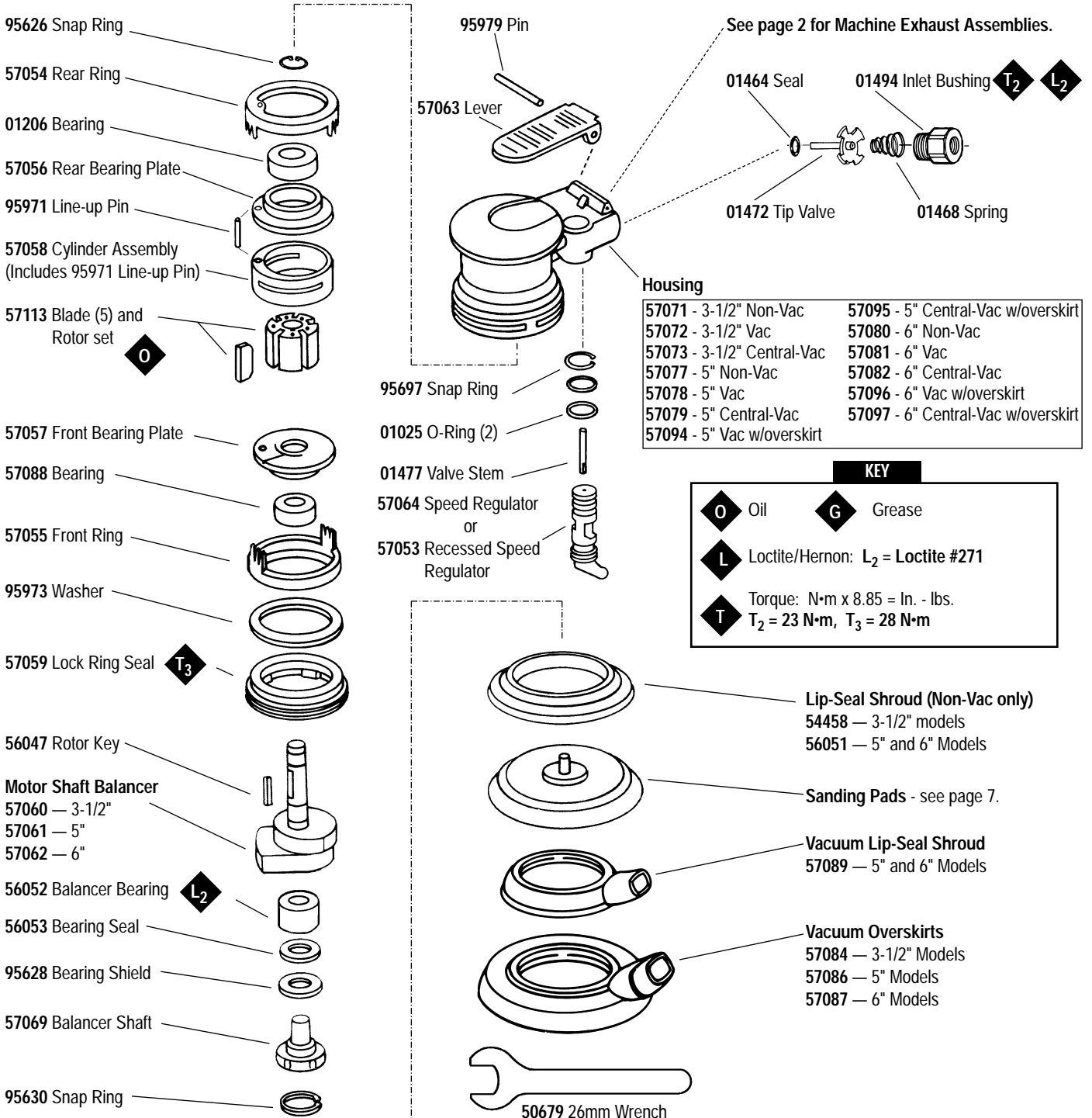

KEY

- O** Oil
- G** Grease
- L** Loctite/Hernon: **L₂** = Loctite #271
- T** Torque: $N \cdot m \times 8.85 = \text{In.} \cdot \text{lbs.}$
T₂ = 23 N•m, **T₃** = 28 N•m

Note: To order replacement parts specify the model and serial number of your machine.

Machine Exhaust Assemblies

Self Generated Vacuum (Vac-Ready)/Machine Exhaust

For Models: 57001, 57002, 57003, 57016, 57017, 57018, 57021, 57022, 57023, 57027, 57028, 57029, 57032, 57033, 57034

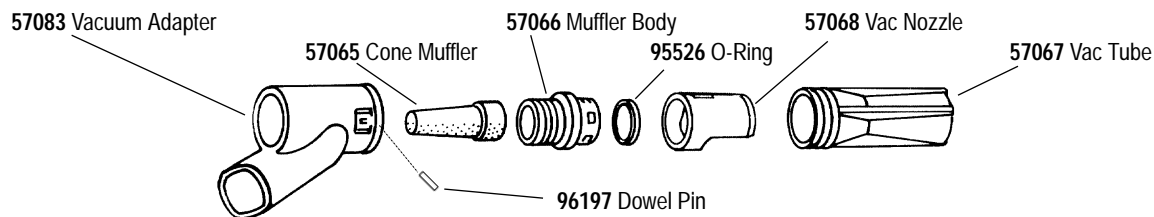

Central Vacuum/Machine Exhaust

For Models: 57004, 57019, 57024, 57030, 57035

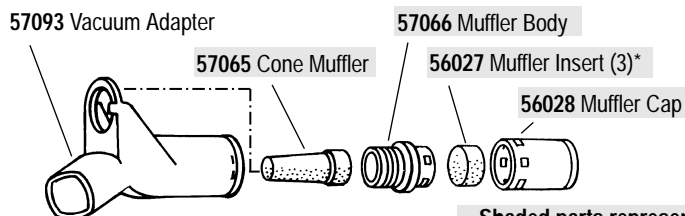

Non-Vacuum/Machine Exhaust

For Models: 57000, 57015, 57026

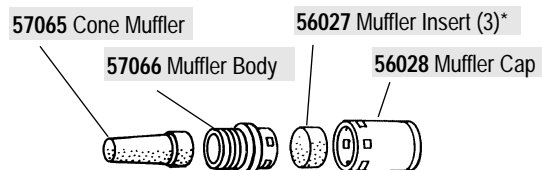

Shaded parts represent 57112 Muffler assembly.

Vacuum Conversion Instructions

To Disassemble:

1. Disconnect tool from power source. Invert machine and secure in vise, using **57092** Collar (supplied in **57098** Repair Kit) or padded jaws.
2. Remove sanding pad with **50679** (26mm) Open-End Wrench (supplied with sander) and lip-seal shroud from housing.
3. Remove **56028** Muffler Cap and **56027** Muffler Insert (3) from **57066** Muffler Body. Using a 12mm hex wrench (supplied in **57098** Repair Kit), remove muffler body and **57065** Cone Muffler from housing (not applicable for Self-Generated Vac to Central Vac).

Non-Vac to Self-Generated Vac for Hook-Up to Self-Contained Dust Collection System

1. Attach **57083** Vacuum Adapter to either **57086**, **57087** Vacuum Overshirts or **57089** Vacuum Lip-Seal Shroud. Then attach to the housing making sure the protrusions on the overshirt or shroud are aligned with the notches on the housing.
2. Place **95526** O-Ring on the muffler body between the shoulder and the four (4) protrusions. Using a 12mm hex wrench, attach the muffler body, cone muffler and O-ring to the housing through the vacuum adapter.
3. Place vacuum nozzle into the vacuum adapter with the slots facing outward making sure that the knob on the nozzle is aligned with the slot in the adapter.
4. Place **57067** Vacuum Tube into the vacuum adapter with the grooves facing inward until the adapter “snaps” onto the tube and the tube cannot be pulled out. If the tube can be pulled out, rotate it 1/4 turn and place it back into the adapter until it “snaps”.
5. Rotate tube until holes line up. Insert dowel pin in holes until it is centered. Attach sanding pad, attach machine to portable dust collection system.

Non-Vac to Central Vac

1. Attach **57093** Vacuum Adapter to either **57086**, **57087** Vacuum Overshirts or **57089** Vacuum Lip-Seal Shroud. Then attach to the housing making sure the protrusions on the overshirt or shroud are aligned with the notches on the housing.
2. Using a 12mm hex wrench, attach the muffler body and cone muffler to the housing through the central vacuum adapter.
3. Place muffler cap with inserts on muffler body making sure that the protrusions on the body fit in the pockets on the cap.
4. Attach weight-mated vacuum sanding pad with **50679** (26mm) Open-End Wrench. Attach machine to central vacuum system.

Self-Generated Vac to Central Vac

1. Remove **96197** Dowel Pin with an 1/8" drive pin. Remove **57067** Vacuum Tube from **57083** Vacuum Adapter by turning it clockwise while pulling backwards.
2. Using a small flat screwdriver, pry vacuum nozzle until it is loose and then remove it by using two fingers to push and pull it until it hits the “legs” on vacuum adapter. Place vacuum tube back into vacuum adapter far enough to push the “legs” back then push vacuum nozzle and vacuum tube out the rest of way.
3. Using a 12mm hex wrench (supplied in **57098** Repair Kit), remove the **57066** Muffler Body, **57065** Cone Muffler and **95526** O-Ring from the housing through the adapter. Remove the O-ring from the muffler body.
4. Remove **57083** Vacuum Adapter and attach **57093** Vacuum Adapter to either **57086**, **57087** Vacuum Overshirts or **57089** Vacuum Lip-Seal Shroud. Then attach to the housing making sure that the protrusions on the overshirt or shroud are aligned with the notches on the housing.
5. Using a 12mm hex wrench, attach the muffler body, cone muffler and O-ring to the housing through the central vacuum adapter.
6. Place muffler cap with inserts on muffler body making sure that the protrusions on the body fit in the pockets on the cap. Attach sanding pad.

Central Vac to Self Generated Vac

1. Remove **57093** Central Vacuum Adapter and put the **57083** Vacuum Adapter in its place.
2. Place **95526** “O” Ring on the muffler body between the shoulder and the four (4) protrusions. Using a 12mm hex wrench (supplied in **57098** Repair Kit), attach the muffler body, cone muffler and O-ring to the housing through the vacuum adapter.
3. Place vacuum nozzle into the vacuum adapter with the slots facing outward making sure that the knob on the nozzle is aligned with the slot in the adapter.
4. Place **57067** Vacuum Tube into the vacuum adapter with the grooves facing inward until the adapter “snaps” onto the tube and the tube cannot be pulled out. If the tube can be pulled out, rotate it 1/4 turn and place it back into the adapter until it “snaps”.
5. Rotate tube until holes line up. Insert **96197** Dowel Pin in holes until it is centered. Attach machine to portable dust collection system.

Important Operating, Maintenance and Safety Instructions

Carefully read all instructions before operating or servicing any Dynabrade® Abrasive Power Tool.

Warning: Hand, wrist and arm injury may result from repetitive work motion and overexposure to vibration.

Important: All Dynabrade air tools must be used with a Filter-Regulator-Lubricator to maintain all warranties.

Operating Instructions:

Warning: Eye, face and body protection must be worn while operating power tools. Failure to do so may result in serious injury or death. Follow safety procedures posted in workplace.

1. With power source disconnected from tool, securely fasten abrasive/accessory on tool.
2. Install air fitting into inlet bushing of tool. **Important:** Secure inlet bushing of tool with a wrench before attempting to install the air fitting to avoid damaging valve body housing.
3. Connect power source to tool. Be careful not to depress throttle lever in the process.
4. Check tool speed with tachometer. If tool is operating at a higher speed than the RPM marked on the tool or operating improperly, the tool should be serviced to correct the cause before use.

Maintenance Instructions:

1. Check tool speed regularly with a tachometer. If tool is operating at a higher speed than the RPM marked on the tool, the tool should be serviced to correct the cause before use.
2. Some silencers on air tools may clog with use. Clean and replace as required.
3. All Dynabrade air motors should be lubricated. Dynabrade recommends one drop of air lube per minute for each 10 SCFM (example : if the tool specification state 40 SCFM, set the drip rate of your filter-lubricator at 4 drops per minute). Dynabrade Air Lube (P/N 95842: 1pt. 473ml.) is recommended.
4. An air line filter-regulator-lubricator must be used with this air tool to maintain all warranties. Dynabrade recommends the following: **11289** Air Line Filter-Regulator-Lubricator — Provides accurate air pressure regulation, two-stage filtration of water contaminants and micro-mist lubrication of pneumatic components. Operates 40 CFM @ 100 PSI has 3/8" NPT female ports.
5. Use only genuine Dynabrade replacement parts. To reorder replacement parts, specify the **Model #**, **Serial #**, and **RPM** of your machine.
6. A motor tune-up kit (P/N 96024) is available which includes assorted parts to help maintain motor in peak operating condition.
7. Mineral spirits are recommended when cleaning the tool and parts. Do not clean tool or parts with any solvents or oils containing acids, esters, keytones, chlorinated hydrocarbons or nitro carbons.

Safety Instructions:

Products offered by Dynabrade should not be converted or otherwise altered from original design without expressed written consent from Dynabrade, Inc.

- **Important:** User of tool is responsible for following accepted safety codes such as those published by the American National Standards Institute (ANSI).
- Operate machine for one minute before application to workpiece to determine if machine is working properly and safely before work begins.
- Always disconnect power supply before changing abrasive/accessory or making machine adjustments.
- Inspect abrasives/accessories for damage or defects prior to installation on tools.
- Please refer to Dynabrade's Warning/Safety Operating Instructions Tag (Reorder No. 95903) for more complete safety information.

Notice

All Dynabrade motors use the highest quality parts and metals available and are machined to exacting tolerances. The failure of quality pneumatic motors can most often be traced to an unclean air supply or the lack of lubrication. Air pressure easily forces dirt or water contained in the air supply into motor bearings causing early failure. It often scores the cylinder walls and the rotor blades resulting in limited efficiency and power. Our warranty obligation is contingent upon proper use of our tools and cannot apply to equipment which has been subjected to misuse such as unclean air, wet air or a lack of lubrication during the use of this tool.

One Year Warranty

Following the reasonable assumption that any inherent defect which might prevail in a product will become apparent to the user within one year from the date of purchase, all equipment of our manufacture is warranted against defects in workmanship and materials under normal use and service. We shall repair or replace at our factory, any equipment or part thereof which shall, within one year after delivery to the original purchaser, indicate upon our examination to have been defective. Our obligation is contingent upon proper use of Dynabrade tools in accordance with factory recommendations, instructions and safety practices. It shall not apply to equipment which has been subject to misuse, negligence, accident or tampering in any way so as to affect its normal performance. Normally wearable parts such as bearings, contact wheels, rotor blades, etc., are not covered under this warranty.

Motor Assembly/Disassembly Instructions – Dynorbital® Supreme Sander

Important: Manufacturers warranty is void if tool is disassembled before warranty expires.

A complete repair kit, part number 57098, is available which includes special tools for correct disassembly/assembly of tool.

To Disassemble

1. Disconnect tool from power source.
2. Invert machine and secure in vice, using 57092 Collar (supplied in 57098 Repair Kit) or padded jaws.
3. Remove sanding pad with 26 mm open-end wrench (supplied with sander) and shroud or overskirt.
4. Insert 56058 Lock Ring Tool (supplied in 57098 Repair Kit) into corresponding tabs of lock ring and unscrew. Motor may now be lifted out for service.
Note: To get it started try using 26 mm wrench for leverage or rock the motor back and forth to loosen up the rings.
5. Remove lock ring, washer, front ring and rear ring from motor. Upper motor may now be disassembled. Remove 95626 Snap Ring
6. Remove the rear plate and the cylinder assembly by securing the cylinder in a bearing separator gripped on the cylinder exhaust and extra pocket area. Push the motor shaft balancer through the bearing.
7. Remove the rotor, vanes and rotor key from the motor shaft balancer. Remove the front plate using a small (#2) arbor press. Support the edges of the front plate while pressing on the small end of the motor shaft balancer.
8. a.) If, during step 7, the front plate and 57088 Bearing remain together, press 57088 Bearing out of the front plate using 57091 Press Tool (supplied in 57098 Repair Kit) as shown in Drawing 1.
b.) If, during step 7, the front plate and 57088 Bearing remains on the motor shaft balancer, it can be removed with a bearing separator.
9. Remove 01206 Bearing from the rear plate by using a bearing press tool.
10. Disassemble the balancer assembly as follows:
 - a.) Place motor shaft assembly into a soft jaw vise. Using a thin screwdriver, pick out the end of 95630 Snap Ring and peel out. This will loosen the balancer assembly.
 - b.) Screw the threaded portion of the 56056 Bearing Puller (supplied in 57098 Repair Kit) into the 57069 Balancer Shaft and heat the outside of the motor shaft balancer to approximately 200° F (approximately 10 seconds with a propane torch). Now, using the slider weight, pull the assembly out.
 - c.) Press off 56052 Bearing with a bearing separator and remove bearing seal and bearing shield.
11. If during step 10, the 56052 Bearing remains in the motor shaft balancer, it can be removed by the heating the shaft balancer again and using either an inside bearing puller or a blind hole bearing puller.

To Reassemble:

Important: Be certain parts are clean and in good repair before reassembling.

1. Assemble the balancer assembly as follows:
 - a.) Install 95630 Snap Ring onto balancer shaft. Install 95628 Shield with convex face toward hex of balancer shaft.
 - b.) Install 56053 Seal. **Note:** Be certain seal is pressed completely over shaft step.
 - c.) Apply 1 drop of #271 Loctite® (or equivalent) and spread over several places around the inside diameter of the 56052 Bearing and the outside diameter of the 57069 Balancer Shaft.
 - d.) Press fit 56052 Bearing with seal side toward hex of balancer shaft up to shaft step as shown in Drawing 2. This must be a firm press fit for proper retention of bearing.
2. Place the motor shaft balancer in a soft jaw vise with large end-up.
3. Apply 1 drop of #271 Loctite® (or equivalent) and spread over several places around the outside diameter of the 56052 Bearing and slide balancer assembly into the motor shaft balancer until 56052 Bearing is firmly seated at bottom. Squeeze 95630 Snap Ring into groove in motor shaft balancer to complete the assembly. Remove from vise.
4. Press 57088 Bearing onto the motor shaft balancer down to the shoulder as shown in Drawing 3.
5. Press 57057 Front Bearing Plate onto 57088 Bearing as shown in Drawing 4 and check for smooth rotation.
6. Place the 57090 Rotor and 56047 Rotor Key on the motor shaft balancer. Place the 56073 Vanes into the rotor slots.
Note: Vanes should be lightly lubricated with Dynabrade Air Lube P/N 95842 (or equivalent) before installation.
7. Place 57058 Cylinder Assembly over rotor. The "short" line-up pin goes toward the Front Plate.
8. Place 57056 Rear Bearing Plate (with 01206 Rear Bearing pressed into place) over shaft and "long" end of line-up pin and press fit in place as shown in Drawing 5.
9. Place 95626 Snap Ring in groove.
10. Place 57054 Rear Ring over the rear plate and line-up pin. Turn the motor over and place 57055 Front Ring over the front plate making sure that the "legs and fingers" on the front and rear rings line-up. Also the small cut-outs on both rings should line-up with the square holes in the cylinder/endplate assembly.
11. Place 95973 Washer and 57059 Lock Ring onto the front ring with 1 drop of pneumatic tool oil spread between the washer and lock ring.
12. Secure motor housing in vise, using 57092 Collar or padded jaws. Spread 2-3 drops of pneumatic tool oil around the housing bore for ease of insertion of motor assembly. Slide motor assembly into secured housing.
Note: Be certain line-up pin enters the pocket in the bottom of the housing and the "legs" of the rings stay in line.
13. Tighten lock ring with 56058 Lock Ring Tool to 28 N·m/250 in. - lbs. Attach shroud or overskirt and weight-mated sanding pad.

Tool assembly is complete. Please allow 30 minutes for adhesives to cure before operating tool.

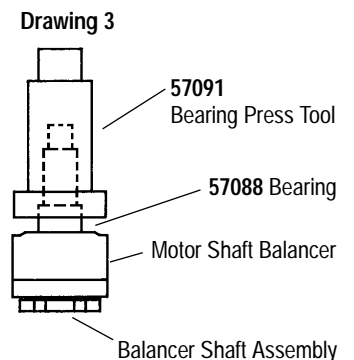
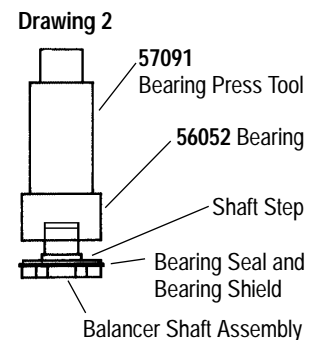
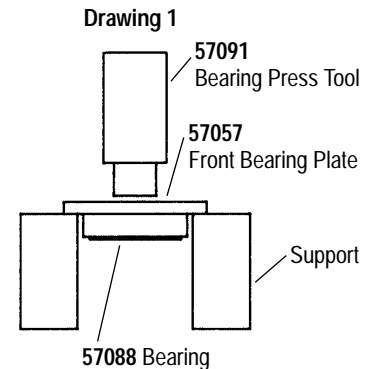

(continued on next page)

Motor Assembly/Disassembly Instructions – Dynorbital® Supreme Sander

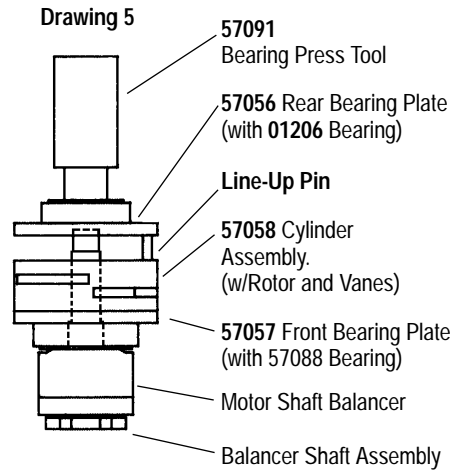
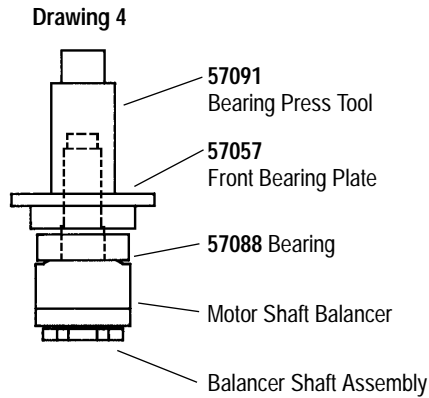

Valve and Speed Regulator Assemblies:

1. Secure housing in vice using 57092 Collar or padded jaws.
2. Remove inlet bushing, 01468 Spring, hinge valve and 01464 Seal from housing.
3. Remove 95697 Snap Ring. Press the spread regulator and valve stem out of the housing. Remove the 01025 O-Rings (2).
4. Place new 01025 O-Rings (2) on the speed regulator and place in housing with valve stem. Install new 95967 Snap Ring.
5. Place new 01464 Seal in housing, . Using tweezers or needle nose pliers, place the tip valve into housing so that the pin goes through the valve stem hole. Place new 01468 Spring into housing so small end is towards tip valve.
6. Spread 1 drop of #271 Loctite® (or equivalent) around the threads of the first inlet bushing and tighten into housing to 23 N·m/200 in. - lbs.

Note: Motor should operate at between 9,500 and 10,000 RPM at 6.2 bar (90 PSI). RPM should be checked with a reed tachometer. Before operating, we recommend that 2-3 drops of Dynabrade Air Lube P/N 95842 (or equivalent) be placed directly into the air inlet with throttle lever depressed. Operate the machine for approximately 30 seconds before application to workpiece to determine if machine is working properly and safely and to allow lubricating oils to properly disperse through machine.

Loctite® is a registered trademark of the Loctite Corp.

Disc Pad Change:

1. Insert 50679 Wrench on flats of 57069 Balancer Shaft and twist off sanding pad by hand.
2. With wrench still in place, hand tighten new pad on tool.
3. No need to remove shroud or overskirt.

Required Weight of Pads:

- 3-1/2" Models — Use pad weighing 80g.
- 5" Models — Use pad weighing 100g.
- 6" Models — Use pad weighing 130g.

Optional Accessories



96024 Motor Tune-Up Kit:
Includes assorted parts to help maintain motor in tip-top shape.



57098 Motor Repair Kit:
Includes special tools for proper disassembly/assembly of the Dynorbital® Supreme.

Self-Contained Dust Collection Systems

Easily attach to Dynorbital® Supreme Random Orbital Sander – Self-Generated Vac-Ready Models.



50694 Mini-Reusable Cloth Bag

- Mounts directly to any Vac-Ready tool or to any exhaust hose.
- Measures 11" long x 3" wide.
- End opens up - no need to remove bag from tool when emptying.



54284 Mini-Flex-Hose System

- 95580 Air Line 1" dia. x 28" long.
- 50638 Flex-Hose 1" dia. x 18" long.
- 50694 Mini-Reusable Cloth Bag.
- 95362 Rubber Connectors (3) which connect air line to exhaust hose.



50683 Reusable Cloth Bag

- Hook 'n loop end for easy emptying.
- Measures 14-1/2" L x 7-1/2" W.
- Connects to vacuum hose.



50617 & 56303 – 6' Long Flex-Hose

- Both systems include 6' long 50682 Flex-Hose.
- Shown with optional 95361 Air Line (1/4" diameter).

50617: Has 50683 Standard Reusable Cloth Bag with hook 'n loop end for easy emptying.

56303: Has 56304 Zipper-Lock Bag.



56304 Reusable Cloth Bag w/Zipper

- Has zipper-lock end.
- Measures 14-1/2" L x 7-1/2" W.
- Connects to vacuum hose.



95986 Hose Cover (5' long cloth cover)

- Covers air line and exhaust/vacuum hoses (not included).
- Eliminates damage from hoses dragging on the workpiece.



54290 "Bag-in-Box" System

- 95361 Air Line 5' long.
- 50682 Flex-Hose 1" dia. x 6' long.
- 95362 Rubber Connectors (5, attach air line to vacuum hose).
- 95575 Durable Box Receptacle (to house bag and store tool).
- Sample paper bag included. Paper bag reorder: 50692 (400/case) or 50693 (24 per package.)

Machine Specifications

Model Number	Pad Dia. Inch (mm)	Length Inch (mm)	Height Inch (mm)	Machine Weight	Spindle Thread	Noise Level	Air Inlet Thread	Hose Size	Air Pressure	RPM
57000	3-1/2" (89)	6" (152)	3-3/4" (95)	2.1 lbs. (1.0 kg)	5/16"-24 female	73 dB(A)	1/4" NPT	1/4"	90 PSI	10,000
57001	3-1/2" (89)	8-1/4" (209)	3-3/4" (95)	2.1 lbs. (1.0 kg)	5/16"-24 female	73 dB(A)	1/4" NPT	1/4"	90 PSI	10,000
57004	3-1/2" (89)	7" (177)	3-3/4" (95)	2.1 lbs. (1.0 kg)	5/16"-24 female	73 dB(A)	1/4" NPT	1/4"	90 PSI	10,000
57015	5" (127)	6-1/2" (165)	3-5/8" (92)	2.1 lbs. (1.0 kg)	5/16"-24 female	73 dB(A)	1/4" NPT	1/4"	90 PSI	10,000
57018	5" (127)	8-1/2" (216)	3-5/8" (92)	2.1 lbs. (1.0 kg)	5/16"-24 female	73 dB(A)	1/4" NPT	1/4"	90 PSI	10,000
57019	5" (127)	7-1/4" (184)	3-5/8" (92)	2.1 lbs. (1.0 kg)	5/16"-24 female	73 dB(A)	1/4" NPT	1/4"	90 PSI	10,000
57023	5" (127)	8-3/4" (222)	3-5/8" (92)	2.1 lbs. (1.0 kg)	5/16"-24 female	73 dB(A)	1/4" NPT	1/4"	90 PSI	10,000
57024	5" (127)	7-1/2" (184)	3-5/8" (92)	2.1 lbs. (1.0 kg)	5/16"-24 female	73 dB(A)	1/4" NPT	1/4"	90 PSI	10,000
57026	6" (152)	8-3/4" (222)	3-1/2" (89)	2.1 lbs. (1.0 kg)	5/16"-24 female	73 dB(A)	1/4" NPT	1/4"	90 PSI	10,000
57029	6" (152)	7" (177)	3-1/2" (89)	2.1 lbs. (1.0 kg)	5/16"-24 female	73 dB(A)	1/4" NPT	1/4"	90 PSI	10,000
57030	6" (152)	7-3/4" (196)	3-1/2" (89)	2.1 lbs. (1.0 kg)	5/16"-24 female	73 dB(A)	1/4" NPT	1/4"	90 PSI	10,000
57034	6" (152)	9-1/4" (235)	3-1/2" (89)	2.4 lbs. (1.1 kg)	5/16"-24 female	73 dB(A)	1/4" NPT	1/4"	90 PSI	10,000
57035	6" (152)	8" (203)	3-1/2" (89)	2.4 lbs. (1.1 kg)	5/16"-24 female	73 dB(A)	1/4" NPT	1/4"	90 PSI	10,000

Random Orbital Sanding Pads

Perfectly balanced and weight-mated to Dynorbital® Supreme Random Orbital Sander.



Premium Urethane Pad - Vinyl Face for PSA-Type Discs					
Pad Description	3-1/2" Dual Purpose	5"		6"	
		Non-Vac	Vac	Non-Vac	Vac
3/8" Thick, Soft Density	—	56102	56100	56103	56101
3/8" Thick, Medium Density	—	56106	56104	56107	56105
5/8" Thick, Soft Density	56097	56185	56186	56187	56188
5/8" Thick, Medium Density	56098	56175	56176	56177	56178

- Premium urethane pads, available in soft or medium density, resist heat build-up.
- New 5/8" thick pads, ideal for sanding of intricate contours.
- Unique vinyl surface pads provide excellent disc adhesion, allowing for quick removal of used discs.

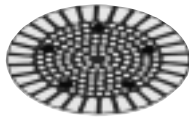

Rubber Pad, Medium Density - Vinyl Face Pads for PSA-Type Discs					
Pad Description	3-1/2" Dual Purpose	5"		6"	
		Non-Vac	Vac	Non-Vac	Vac
1/2" Thick, "Diamond Pattern Face"	—	50630	50631	50632	56101
1/2" Thick, "Post Pattern Face"	—	—	50695	—	50696

- Special rubber/vinyl face pads for PSA discs.
- "Post Pattern" design for enhanced vacuum pick-up.
- Unique vinyl surface pads provide excellent disc adhesion, allowing for quick removal of used discs.
- No need to align vacuum holes, saves time on disc changes.



Premium Urethane Pad - Hook Face Short Nap Pads for Scrim-Back Discs					
Pad Description	3-1/2" Dual Purpose	5"		6"	
		Non-Vac	Vac	Non-Vac	Vac
3/8" Thick, Soft Density	—	56157	56155	56158	56156
3/8" Thick, Medium Density	—	54325	54326	54327	54328
5/8" Thick, Soft Density	54311	56195	56196	56197	56198
5/8" Thick, Medium Density	54313	56180	56181	56182	56183

- Hook face "short nap" pads for reattachable discs.

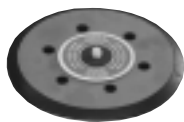

Rubber, Medium Density - Hook Face Long Nap Pads for Non-Woven Nylon Discs					
Pad Description	3-1/2" Dual Purpose	5"		6"	
		Non-Vac	Vac	Non-Vac	Vac
1/2" Thick, Medium Density	54314	50605	50607	50606	50610

- Hook face "long nap" pads for Abrasive Impregnated Non-Woven Nylon Discs.

- 3-1/2", 5" and 6" diameter disc pads have 5/16"-24 male threaded stud.
- The 3-1/2" diameter discs, without holes, can be used on vacuum and non-vacuum 3-1/2" Dynorbital® Supreme Sanders.

Coated Abrasive Discs

Silicon Carbide Discs / PSA Mounted

Disc Type	Abrasive Grit					
	80	100	120	150	180	220
5" Diameter						
No Holes	93051	93052	93053	93054	93055	93056
5-Hole Pattern	93060	93061	93062	93063	93064	93065
6" Diameter						
No Holes	93069	93070	93071	93072	93073	93074
6-Hole Pattern	93077	93078	93079	93080	93081	93082

Note: Other grits available upon request.

All Discs: 120 Grit and Coarser – 125/Roll; 8 Rolls = Unit.
150 Grit & Finer – 250/Roll; 4 Rolls = Unit. Complete rolls only.

Premium Aluminum Oxide Discs / PSA Mounted

Disc Type	Abrasive Grit						
	80	100	120	150	180	220	320
3-1/2" Diameter							
*No Holes	92090	—	92092	—	92094	92095	92097
5" Diameter							
No Holes	93101	93102	93103	93104	93105	93106	—
5-Hole Pattern	93109	93110	93111	93112	93113	93114	—
6" Diameter							
No Holes	93200	93201	93202	93203	93204	93205	—
6-Hole Pattern	93215	93216	93217	93218	93219	93220	—

Note: Other grits available upon request.

*Used on either vacuum or non-vacuum 3-1/2" sander.
All Discs: 120 Grit and Coarser – 125/Roll; 10 Rolls = Unit.
150 Grit and Finer – 175/Roll; 6 Rolls = Unit. Complete rolls only.



Toll Free (U.S.A.) 1-800-828-7333
Toll Free (Can.) 1-800-344-1488

Visit our new Web Site via Industry.Net MROP On-Line: <http://www.dynabrade.industry.net>

E-Mail: DynaTalk@aol.com

DYNABRADE, INC., 8989 Sheridan Drive • Clarence, NY 14031-1490 • Phone: (716) 631-0100 • Fax: 716-631-2073 • International Fax: 716-631-2524
DYNABRADE EUROPE S.à.r.l., Zone Artisanale • L-5485 Wormeldange—Haut, Luxembourg • Telephone: 352 76 84 94 • Fax: 352 76 84 95
©DYNABRADE, INC., 1997 PRINTED IN USA